

JRW

CAST IRON CHECK VALVE BS5153 PN16

- Design and Manufacture Conform to BS5153
- Flange dimensions Conform to BS4504 PN16
- Face to Face dimensions Conform to BS5153 PN16
- Testing Conform to BS6755

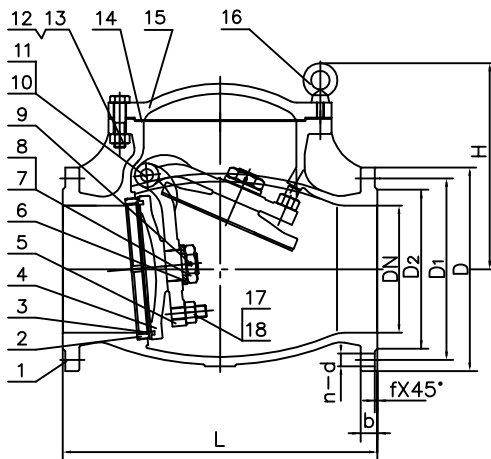

MATERIALS

NO.	PART NAME	MATERIAL(C.I.)	MATERIAL(D.I.)
1	BODY	ASTM A126 B	ASTM A536
2	SEAT RING	ASTM B62 or 13Cr	ASTM B62 or 13Cr
3	DISC SEAL RING	ASTM B62 or 13Cr	ASTM B62 or 13Cr
4	DISC	ASTM A126 B	ASTM A536
5	HINGE	ASTM A216 WCB	ASTM A216 WCB
6	WASHER	CARBON STEEL	CARBON STEEL
7	NUT	CARBON STEEL	CARBON STEEL
8	STUD	CARBON STEEL	CARBON STEEL
9	SPLIT PIN	304	304
10	HINGE PIN	13Cr	13Cr
11	PLUG	ASTM A536	ASTM A536
12	BOLT	CARBON STEEL	CARBON STEEL
13	NUT	CARBON STEEL	CARBON STEEL
14	BONNET GASKET	GRAPHITE+STEEL	GRAPHITE+STEEL
15	BONNET	ASTM A126 B	ASTM A536
16	EYE SCREW	CARBON STEEL	CARBON STEEL
17	ADJUSTING SCREW	CARBON STEEL	CARBON STEEL
18	NUT	CARBON STEEL	CARBON STEEL

DIMENSIONS (mm)

DN	L	D	D ₁	D ₂	b	n-d	f	H	Kg
50	203	165	125	99	20	4-19	3	153	19
65	216	185	145	118	20	4-19	3	162	22
80	241	200	160	132	22	8-19	3	176	30
100	292	220	180	156	24	8-19	3	220	43
125	330	250	210	184	26	8-19	3	226	59
150	356	285	240	211	26	8-23	3	256	78
200	495	340	295	266	30	12-23	3	298	128
250	622	405	355	319	32	12-28	3	376	199
300	698	460	410	370	32	12-28	4	410	305
350	787	520	470	429	36	16-28	4	444	498
400	914	580	525	480	38	16-31	4	501	676
450	965	640	585	548	40	20-31	4	698	781
500	1067	715	650	609	42	20-34	4	742	1008
600	1219	840	770	720	48	20-37	5	844	1610